

Product Specifications

Customer	
Model	NTOD320-2 V500



Revision History			
Version	Revision Item	Previous Description	Updated Description
v2604.1	Initial release		

Nextech OD Series 32" Industrial Waterproof Touch Monitor

NTOD320-2 V500

Key Features

- ★ 32" wide LCD panel 1920x1080 (FHD)
- ★ Wide viewing angle 178°/178°
- ★ Maximum brightness up to 2500 nits (**optional**)
- ★ Full IP68 / IP69K-rated water and dust protection
- ★ Stainless steel enclosure
- ★ Anti-glare and UV-resistant surface treatment
- ★ HDMI video input
- ★ Projected capacitive (PCAP) touch (**optional**)
- ★ Ambient light sensor with automatic brightness adjustment (**optional**)
- ★ Made in Taiwan, 3-year warranty



PSE



BSMI



CE



ISO9001



FCC



Nextech OD Series 32" Industrial Waterproof Touch Monitor

NTOD320-2 V500

Display Specifications

Model Name	NTOD320N<u>X</u>2DA-GGSL<u>X</u>0-500*	Display Mode	Normally Black
Screen Diagonal	32 inch	Response Time	8 msec.
Active Area	698.4x392.85 mm	Backlight	White LED
Resolution	1920x1080 (FHD)	Viewing Angle (L/R, U/D)	178°/178° (CR≥10)
Contrast Ratio	4000:1	Backlight Lifetime	>50,000 hours
Aspect Ratio	16:9	Operating Temp.	0~50°C
Colors	16.7M	Storage Temp.	-20~60°C
Pixel Pitch	0.3637x0.3637 mm		

* X = A-Z, 0-9 (Varies by options)

Brightness Options

Brightness			
Configuration	Brightness	Application	Ordering Information
Standard	500nits	General (Indoor)	NTOD320N<u>X</u>2DA-GGSL<u>X</u>0-600
Optional	1500nits	Outdoor / Semi-outdoor	NTOD320N <u>X</u> 3DA-GGSL <u>X</u> 0-600 *
Optional	2500nits	Outdoor	NTOD320N <u>H</u> 4DA-GGSL <u>X</u> 0-600 *

* Refer to datasheets: NTOD320-3, NTOD320-4

Touch Options

Configuration	Specification	Ordering Information
Standard	Projected Capacitive touch	NTOD320N<u>P</u>2DA-GGSL<u>U</u>0-500
Optional	No touch	NTOD320N <u>0</u> 2DA-GGSL <u>0</u> 0-500

PCAP Touch Specification

Touch Points	10 points	Cover Lens Thickness	3.0±0.2mm
Transparency	≥87%	Cover Lens Hardness	7H
Accuracy	99.00%	IK Ratings	IK07

Nextech OD Series 32" Industrial Waterproof Touch Monitor

NTOD320-2 V500

Included Cables and Power Accessories

Item	Specification	Quantity
HDMI Cable	HDMI Waterproof Connector, 2m	1
USB Cable	USB 3.0 Waterproof Connector, 2m	1
Power cord	* (varies by region)	1

Optional Mounting Accessories

	Accessories	Description
Optional	Desktop stand	For desktop use
Optional	Wall mount bracket	For wall mounting
Optional	Motorized lift cart	Electric height adjustment
Optional	Kiosk enclosure kit	Information kiosk enclosure

Desktop Stand (Optional)

Item	T Stand	Model	DST-1B007
VESA Mount	200x100/100x100/75x75 mm	Dimensions	508(W)x307(D)x470(H) mm
Material	Steel/Plastic/Aluminum	Net Weight	2.44 kg
Tilt Angle	±15°	Load Capacity	15 kg

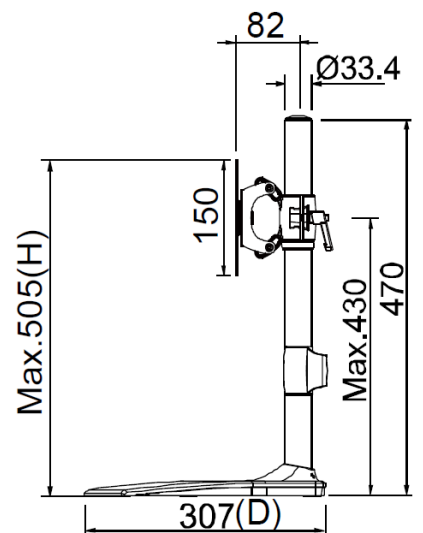
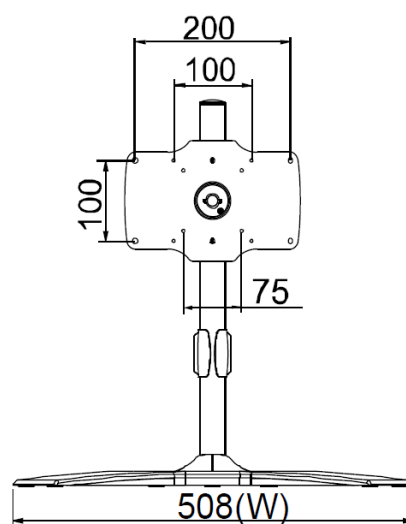

Nextech OD Series 32" Industrial Waterproof Touch Monitor

NTOD320-2 V500

Wall Mount Bracket (Optional)

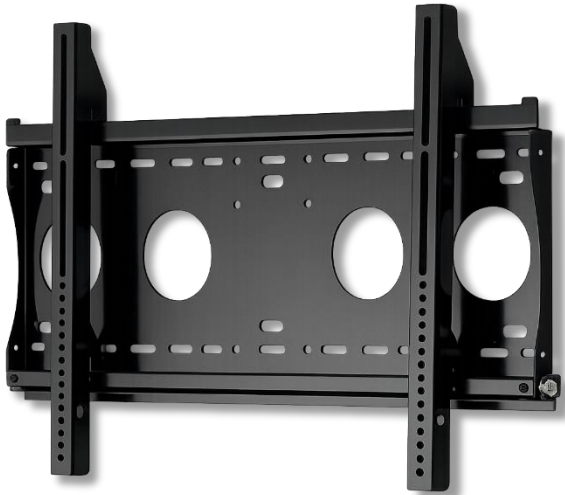

Model	WMB-B001	Dimensions	508x490x48 mm
VESA mount	Max. 400x450 mm	Net Weight	4.01 kg
Material	SECC	Load Capacity	80 kg
Tilt Angle	0°/5°/10°/13°/15°	Min. Wall Distance	48 mm
Mounting Screw	M4/M5/M6/M8		

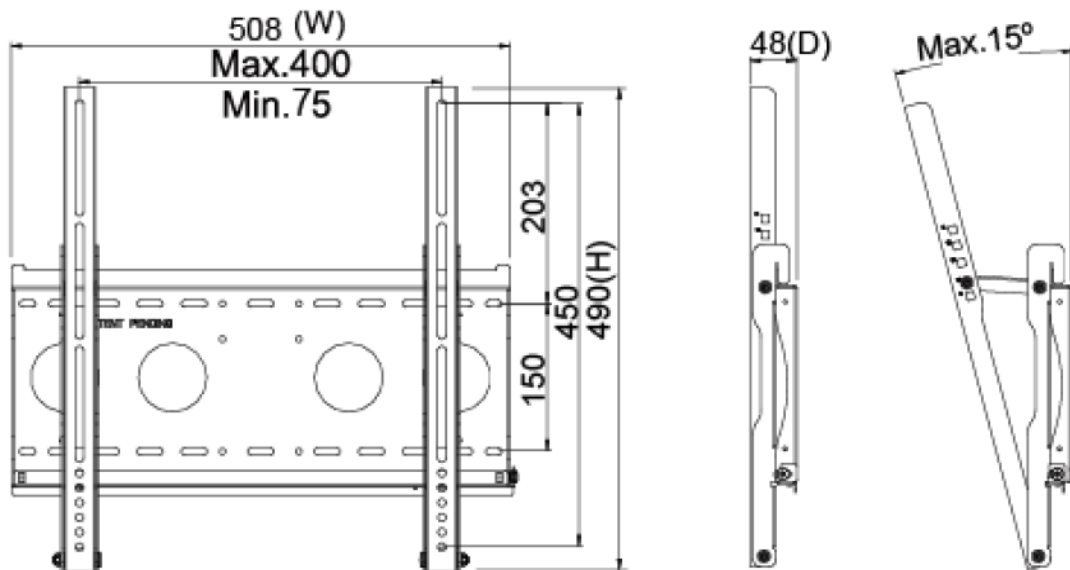

Nextech OD Series 32" Industrial Waterproof Touch Monitor

NTOD320-2 V500

Motorized Lift Cart (Optional)



Net Weight	28.4 kg
Power Input	AC 200-240V 50/60Hz
User Interface	Button (up/down)
Package Dimensions	1160(W)x833(D)x1727(H) mm
Mounting Screw	M4/M5/M6/M8
Material	Aluminum/Plastic/Steel
Max. Mount Pattern	800x600 mm
Load Capacity	80 kg
Caster	4 (front x 2 with brakes)
Height Adjustment Range	455 mm
Compliance	RoHS/REACH

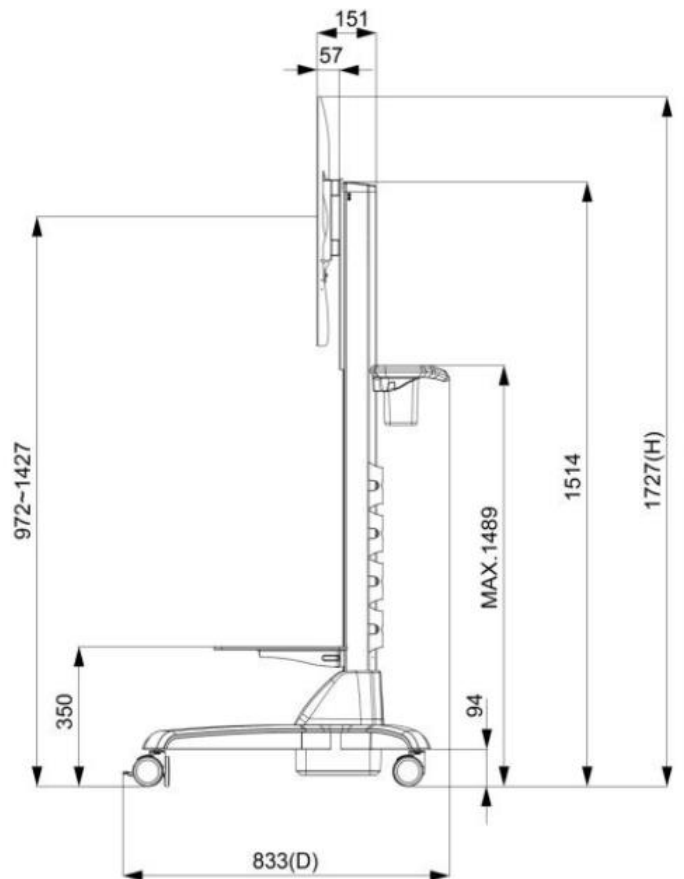
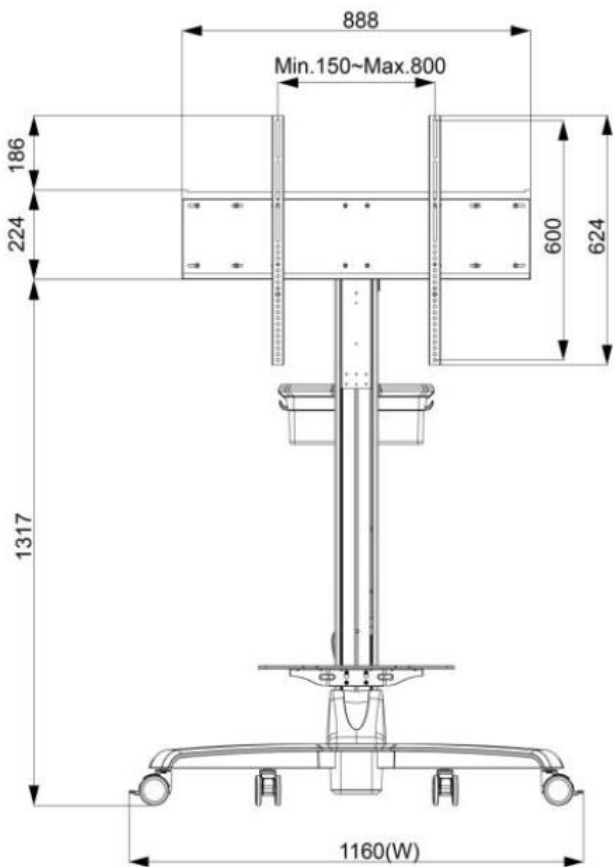

Nextech OD Series 32" Industrial Waterproof Touch Monitor

NTOD320-2 V500

Kiosk Enclosure Kit (Optional)

Material	SECC (Electro-galvanized steel)
Caster	4 (Front × 2 with brakes)
Ingress Protection	Front IP65
Power Input Panel	Not included (pre-cut opening reserved)



Input /Output System

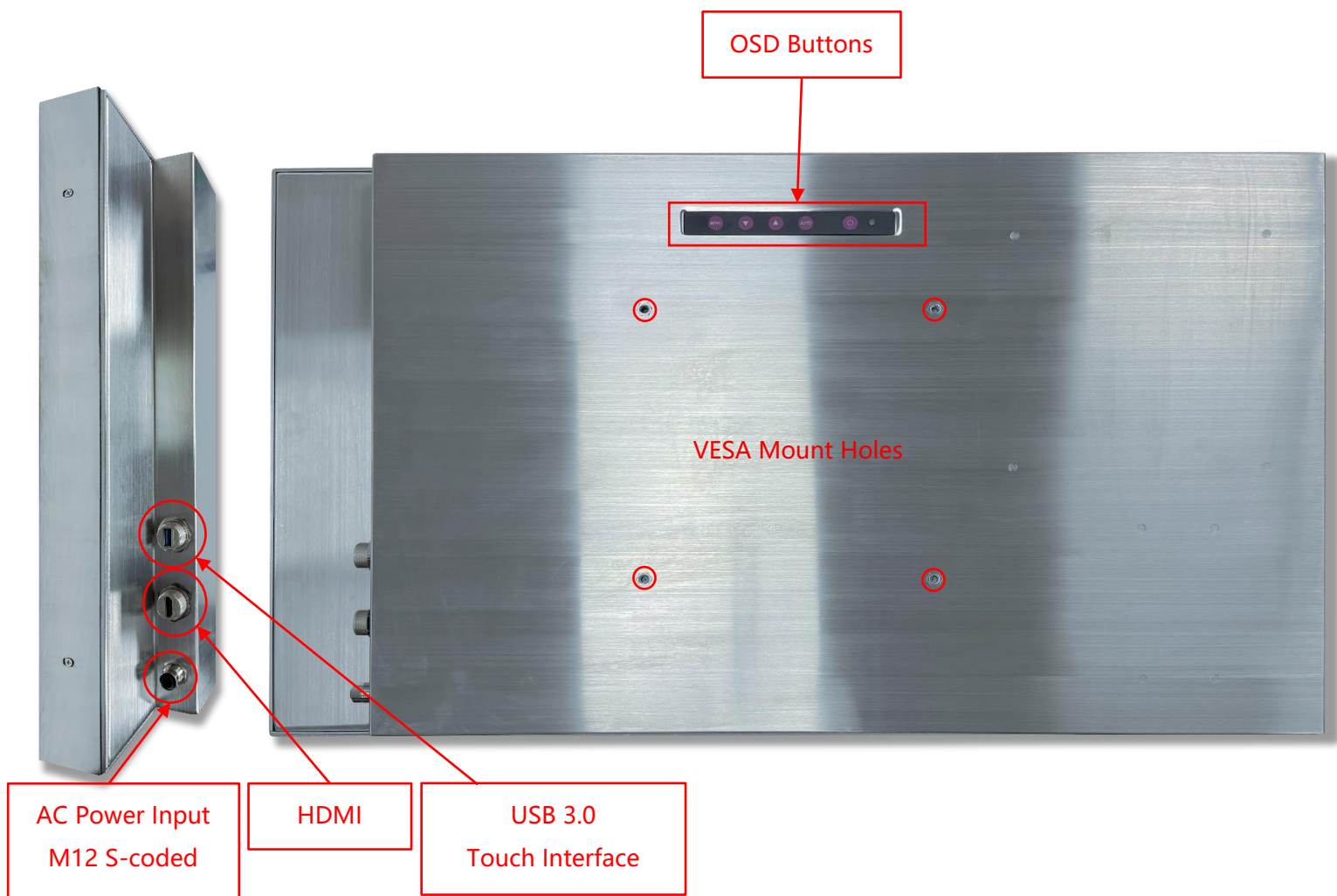

Nextech OD Series 32" Industrial Waterproof Touch Monitor

NTOD320-2 V500

Mechanical Specifications

Dimension (Max)	509.6x315.3x51(±2)mm	Net Weight	≤ 18.6 kg
VESA Mount	100x100 mm	Gross Weight	≤ 22.4 kg

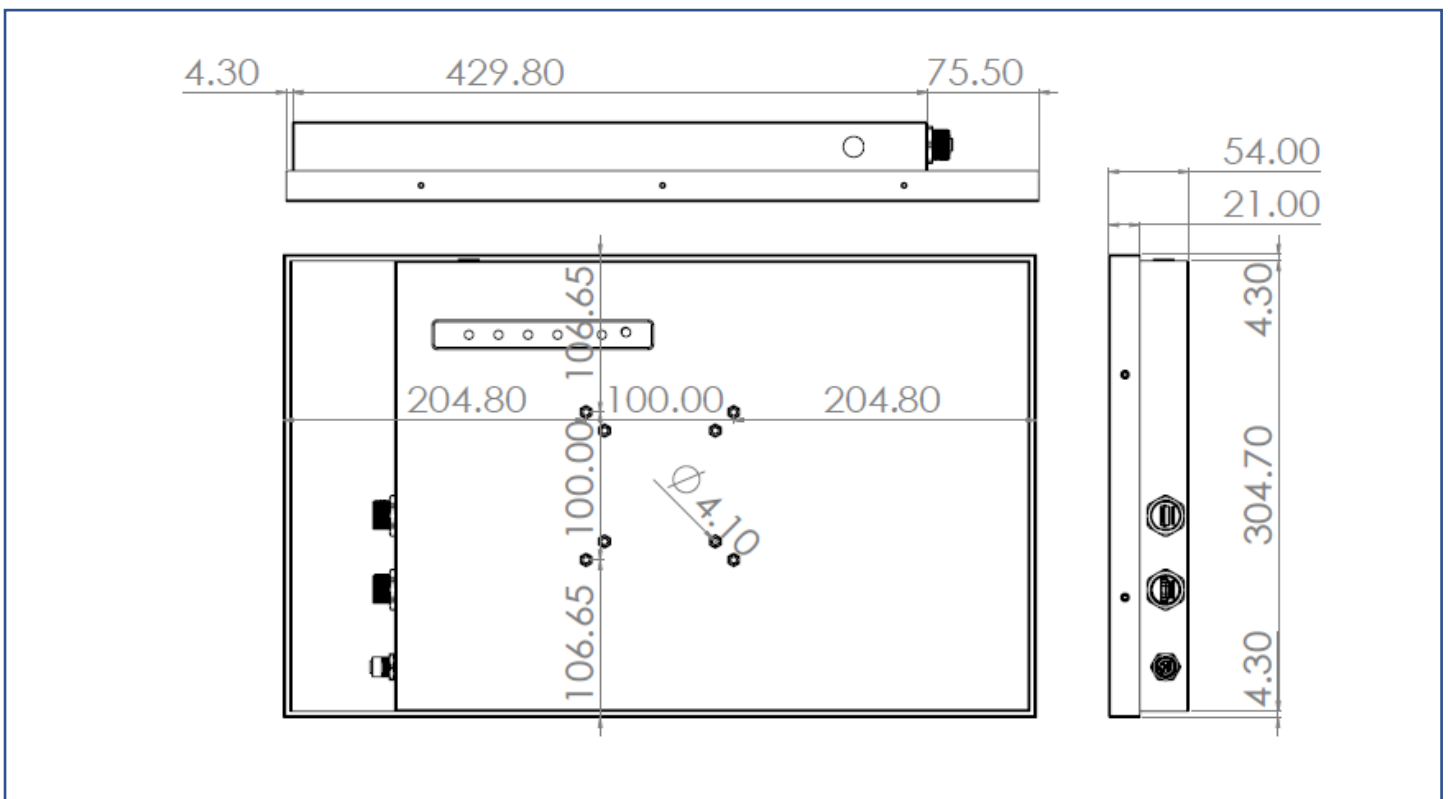
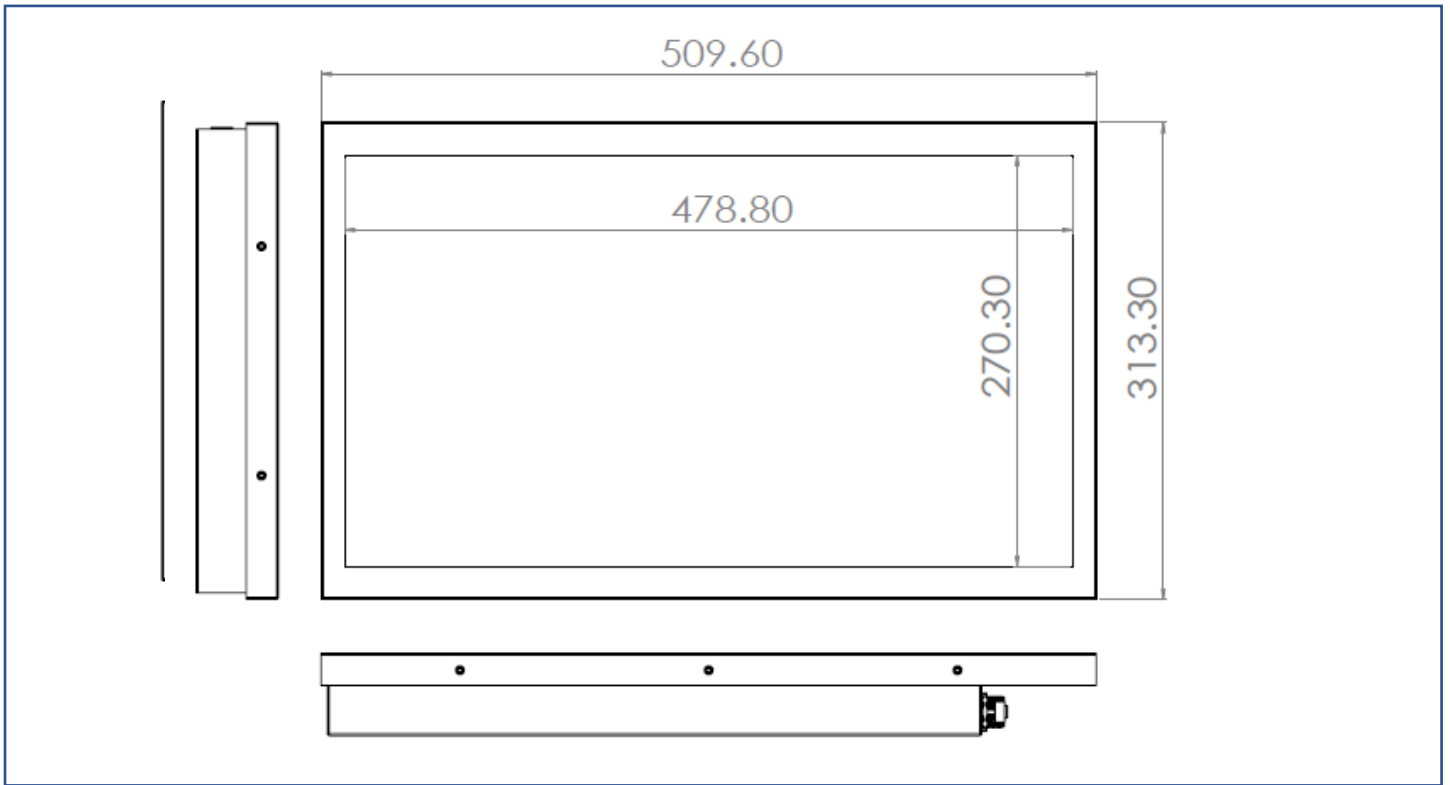

Packaging Information



Package Dimensions	105x24x68 cm
Net Weight	≤ 18.6 kg
Gross Weight	≤ 22.4 kg